

# GENUINE FRONT FOG LAMP KIT

## INSTALLATION INSTRUCTIONS

Thank you for purchasing a genuine Mazda accessory.

Before removal and installation, be sure to thoroughly read these instructions.

Please read the contents of this booklet in order to properly install and use the front fog lamp kit. Your safety depends on it.

Keep these instructions with your vehicle records for future reference.



- There are several **⚠WARNING** and **⚠CAUTION** sections in this booklet concerning safety when installing or removing the front fog lamp kit. Always read and follow them in order to prevent injuries, accidents, and possible damage to the vehicle.

**⚠ WARNING:** Indicates a situation in which serious injury or death could result if the warning is ignored.

**⚠ CAUTION:** Indicates a situation in which bodily injury or damage to the vehicle could result if the caution is ignored.

- For areas indicating the tightening torque in this instruction manual, tighten to the specified torque using a torque wrench. For areas in which the tightening torque is indicated inside parentheses ( ), the tightening torque is indicated as a reference value, however tightening using a torque wrench is not necessary.
- Do not modify the front fog lamp kit.
- Do not install the front fog lamp kit in any way other than described in the following instructions.
- If in any doubt, please ask your Mazda dealer to install the accessory in order to prevent errors in installation.
- If you have any questions about the use of the accessory, ask your Mazda dealer for proper advice before using it.
- Mazda and its suppliers are not responsible for injuries, accidents, and damage to persons and property that arise from the failure of the dealer or installer to follow these instructions.
- To ensure safety and reliability of the work, installation, removal and disposal work must be carried out by an Authorized Mazda Dealership.
- Be careful not to lose removed parts, and be sure that they are kept free from scratches, grease or other dirt.

**PART NAME: FRONT FOG LAMP KIT**

**PART NUMBER: BHN1 V4 600**

**VEHICLE: MAZDA3**

### NOTE

#### To the dealer

- Please turn over these instructions to the customer after installation.

#### To the customer

- Keep these instructions after installation. The instructions may be necessary for installing other optional parts or removal of this accessory.
- Should the vehicle or this accessory be resold, always leave these instructions with it for the next owner.

# 1. INSTALLATION VIEW

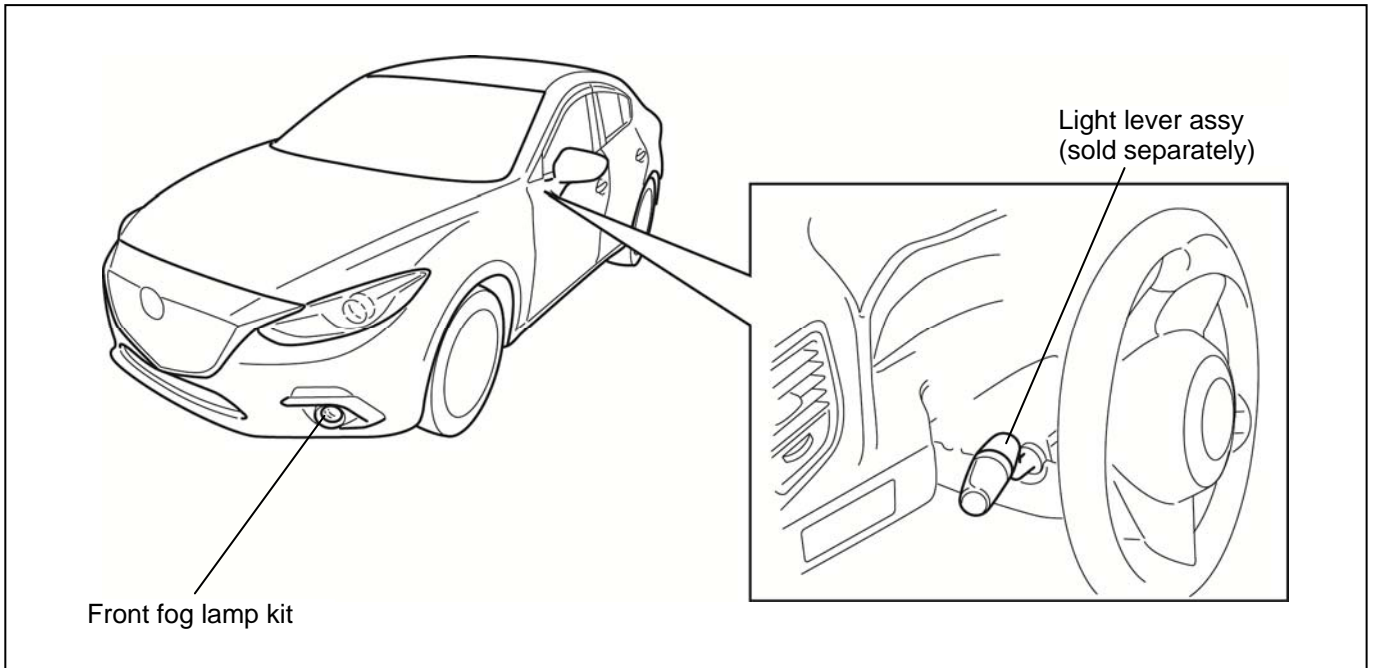

# 2. PARTS

- Before installation, verify that the kit includes all the following parts and that they are free of dirt, scratches, or damage.

Part	Part name	Qty	Part	Part name	Qty	Part	Part name	Qty
	Fog lamp (RH, LH)	2		Fog lamp bracket (RH, LH)	2		Fog lamp cover (RH, LH)	2
SERVICE PARTS SAME AS OE, REFER TO EPC TO ORDER						<b>SEE NOTE BELOW</b>		
	Set screw	2		Screw	2		Tapping screw	6
	Installation Instructions (Three languages: English, French and spanish)	1ea.						

**FOG LAMP COVER (R) BJE1-50-C11A**  
**CHROME RING (R) BJE1-50-C12**  
**FOG LAMP COVER (L) BJE1-50-C21A**  
**CHROME RING (L) BJE1-50-C22**





Sold separately	Part name	Qty
	Light lever assy	1

## 3. BEFORE INSTALLATION

### ■ REQUIRED TOOLS

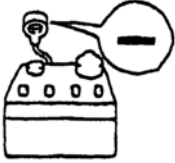
- ☆Screwdriver (Phillips)    ☆Flathead screwdriver    ☆Socket wrench (10mm)    ☆Torque wrench
- ☆Protective tape    ☆Protective sheet    ☆Pliers    ☆Soft, clean cloth

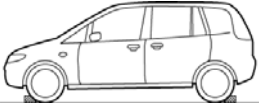
### ⚠ WARNING

<p>When the negative battery cable is connected during operation, it may cause electric shock or other injuries. Disconnect the negative battery cable before removal/installation.</p>	<p>Do not pull wiring harnesses with excessive force. Doing so can cause breakage or a short circuit-related accident, as well as an electrical short or fire.</p>	<p>Park the vehicle on a flat, level surface, set the selector lever to P (AT vehicles) or the shift lever to 1st or R (MT vehicles), apply the parking brake and block the wheels so that the vehicle does not move during installation.</p>	<p>When connecting/disconnecting connectors, grasp the connectors, not the wires. Otherwise a short, an accident from poor contact or fire may occur.</p>
			

### ⚠ CAUTION

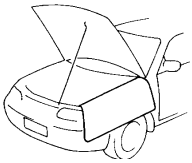
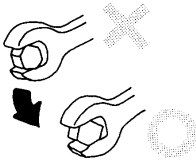
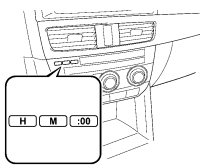
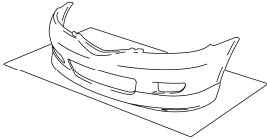
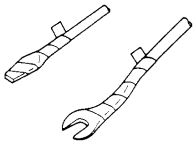
<p>Be sure to cover the vehicle body with protectors or mats to prevent stains, scratches and damage when removing/installing the vehicle parts</p>	<p>Using improper tools may cause damage and or broken parts. Use the correct tool for the job.</p>	<p>When the negative battery cable is removed, the clock, radio, trip meters and other memories will be erased. Before performing work, record the content of the memory.</p>	<p>Put the removed parts and the parts in the kit on the protective sheet to prevent scratches.</p>
			
<p>Wrap protective tape around screwdrivers and fastener remover tools to prevent scratching the vehicle.</p>			
			

### Advice

<p>Refer to the Workshop Manual for removal and installation of vehicle parts. Not following the procedures for removal/installation in the Workshop Manual could result in an accident or vehicle malfunction.</p>

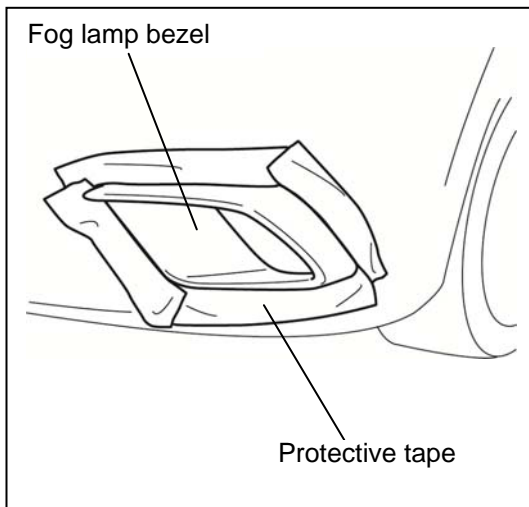

## 4. VEHICLE PART REMOVAL



### Fog lamp bezel removal

- The figure shows the left side, however, the procedure is the same for the right side.

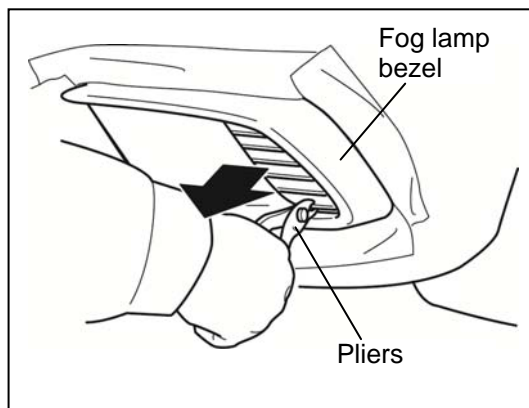
1. Disconnect the negative battery cable.
2. Apply protective tape around the fog lamp bezel on the front bumper and turn lamp.



3. Grasp the fin of the fog lamp bezel using a pair of pliers as shown in the figure and pull it outward to remove.

#### ⚠ CAUTION

- When removing the front fog lamp bezel, do not pull on it with excessive force. Otherwise the wiring harness will be damaged.

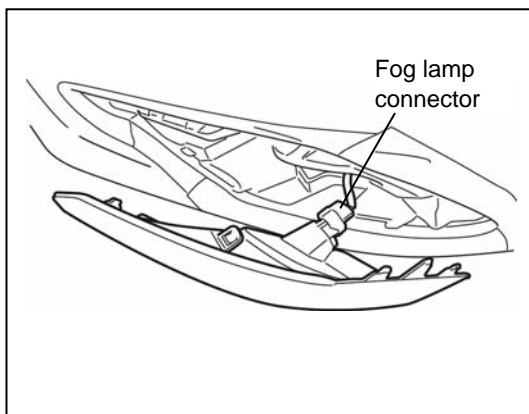

4. Disconnect the fog lamp connector and remove the fog lamp bezel

- The fog lamp bezel cannot be reused.

## 5. INSTALLATION OF THE FOG LAMP KIT

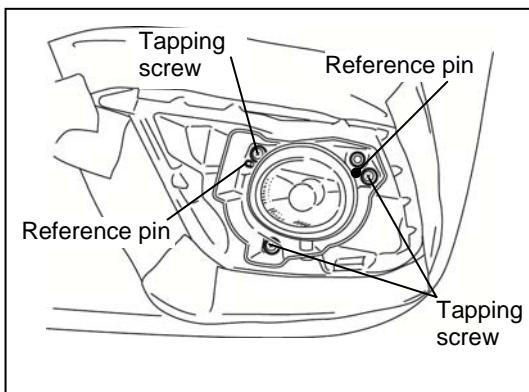
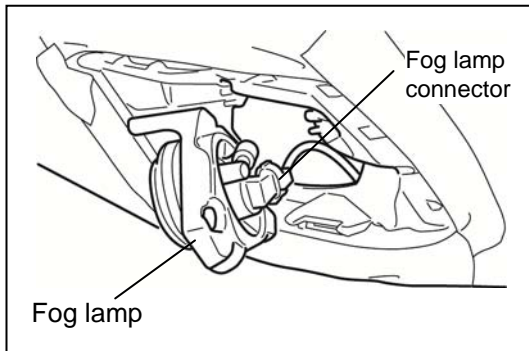
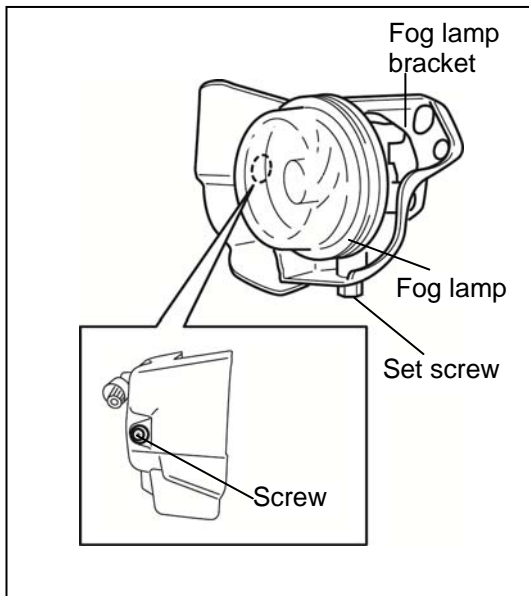

### Install the fog lamp

- The figure shows the left side, however, the procedure is the same for the right side.

1. Install the fog lamp to the fog lamp bracket using the screw (1) and the set screw (1) included with the kit.

**Set screw tightening torque : 1.0–3.4 N·m**

**Screw tightening torque : (0.3–1.5 N·m)**

- Insert the fog lamp into the bracket in the order of arrows (1), (2) and (3).

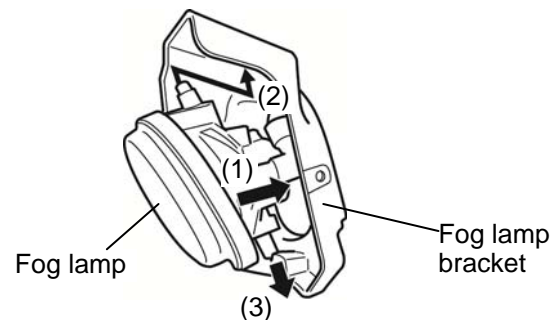

2. Connect the fog lamp connector to the bulb socket.

3. Install the fog lamp and fog lamp bracket to the front bumper using the tapping screws (3) included with the kit.

**Screw tightening torque : (0.3–1.5 N·m)**

- Install the fog lamp covers, after perform the fog lamp aming.

## 6. INSTALLATION OF THE LIGHT LEVER ASSY

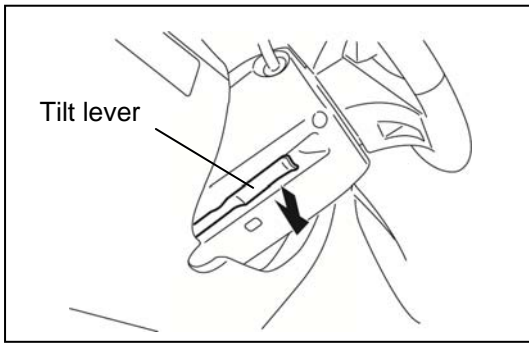

### Column cover removal

1. Lower the tilt lever and unlock the steering.
2. Lower the steering wheel and pull it outward.

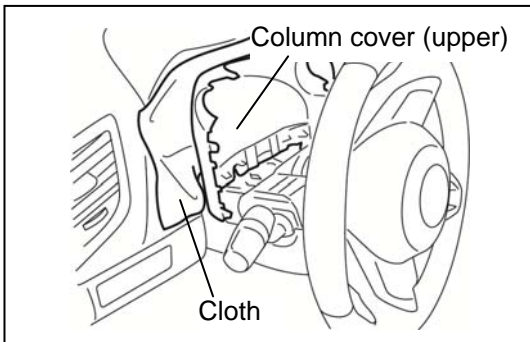

3. Pull the column cover (upper) upward and disconnect it.
4. Lower the column cover (upper) to the instrument cluster side.
  - To prevent damage to the surface of the instrument cluster, cover it with a protective cloth.

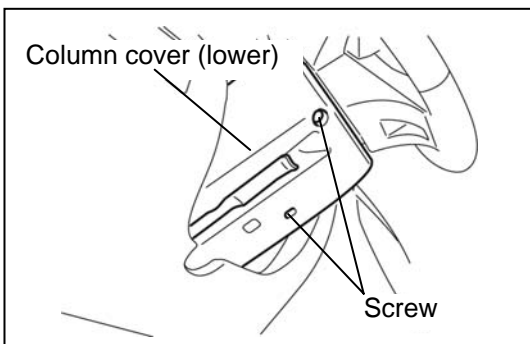

5. Remove the screws (2) and then remove the column cover (lower).

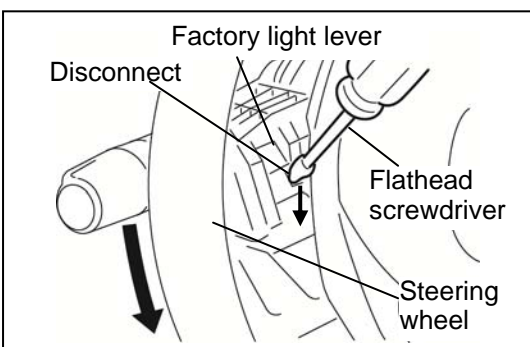

### Install the light lever assy

- The figure shows a vehicle with light lever on left side, however, the procedure is the same for a vehicle with light lever right side.

1. Turn the steering wheel and then disconnect the factory light lever.
2. Remove the factory light lever in the direction of the arrow.
3. Install the new light lever assembly in the reverse order of removal.
4. Install the column covers in the reverse order of removal.

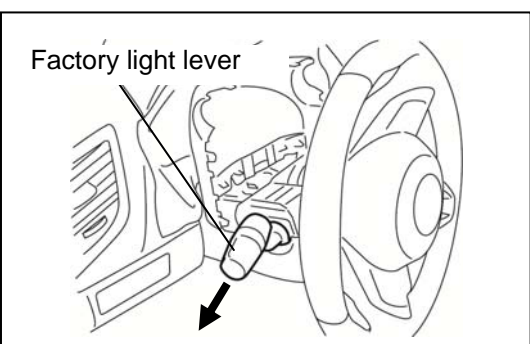

## 7. FOG LIGHT AIMING

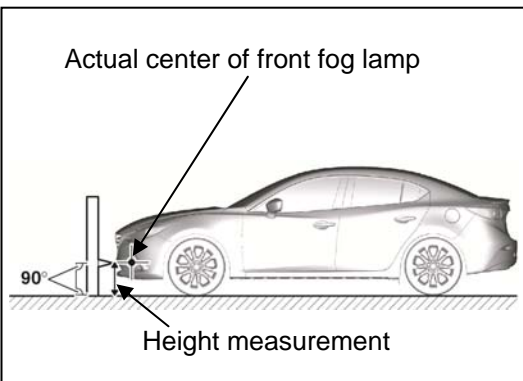
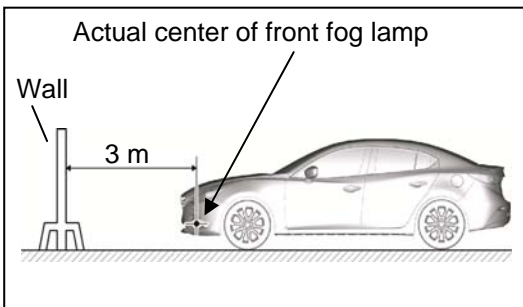
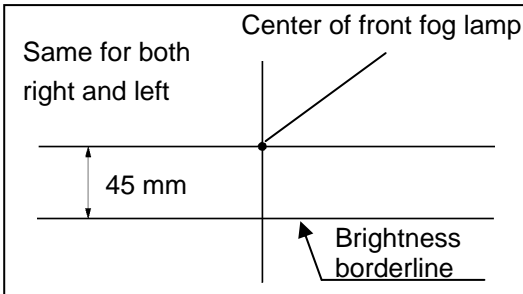

1. Empty the vehicle by having all occupants leave the vehicle and remove all the cargo except for the spare tire, jack and tools equipped on the vehicle.
2. Adjust the air pressure of each tire to the specified value.
3. Move the vehicle to level ground.
4. Sit on the driver-side seat alone.
5. Make an adjustment-use screen as shown in the figure using double-weight, white paper. (Common to both left and right)
6. Line up the vehicle with the wall so that the distance to the fog lamp is 3 m from the wall.

7. Measure the height at the center point of the front fog lamp.

- Measure the height at the center point of the front fog light in which the aiming is being adjusted because the vehicle height differs depending on vehicle conditions.

8. Align the center point of the front fog lamp with the center of the screen.
9. Set a partition in front of the front fog lamp which is not being adjusted to block the light.
10. Start the engine and charge the battery.
11. Turn on the front fog lights.

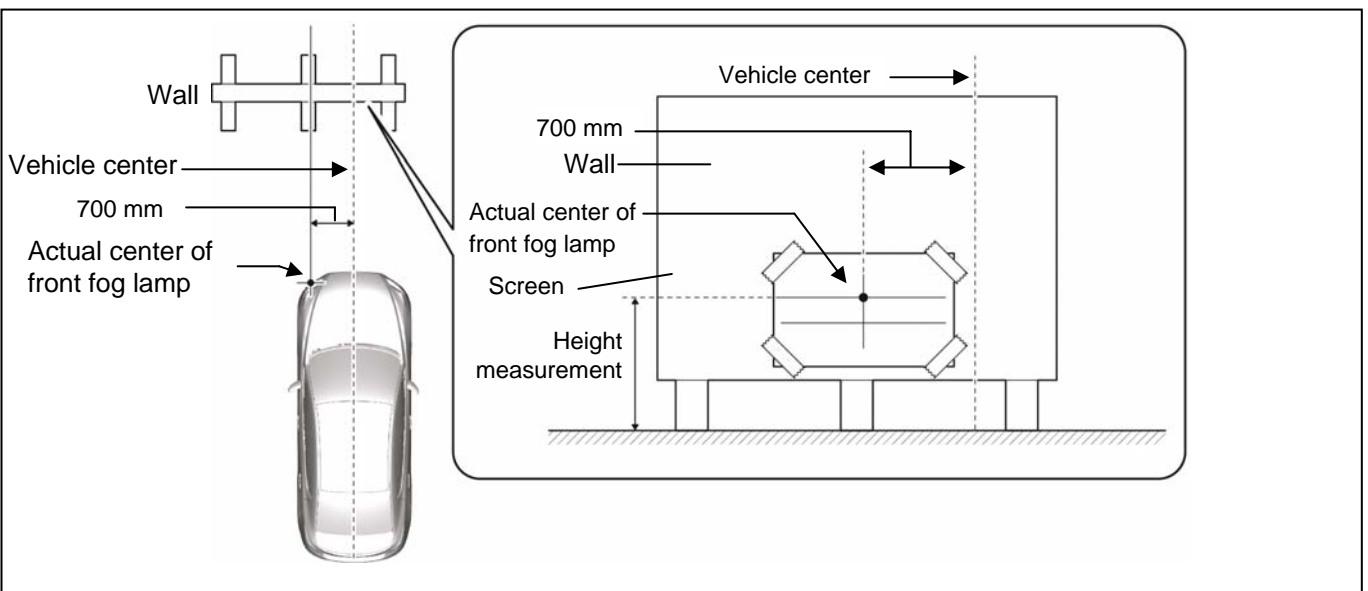

12. Verify that the brightness border line of the front fog lamp is at the position indicated on the adjustment screen.

- If the brightness border line is not at the position indicated on the adjustment screen, perform the following adjustment.

- (1) Disconnect the negative battery cable.
- (2) Remove the bezel.
- (3) Remove the bracket before cutting the front fog light hole cover located on the bolt installation hole.

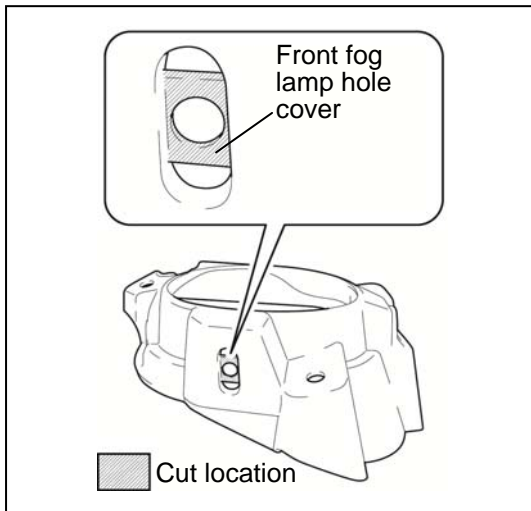

(4) Cutout the hatch-marked area of the front fog light hole cover shown in the figure.

- Remove all the shaded area shown in the figure so that the front fog light hole cover does not interfere with the bolt.

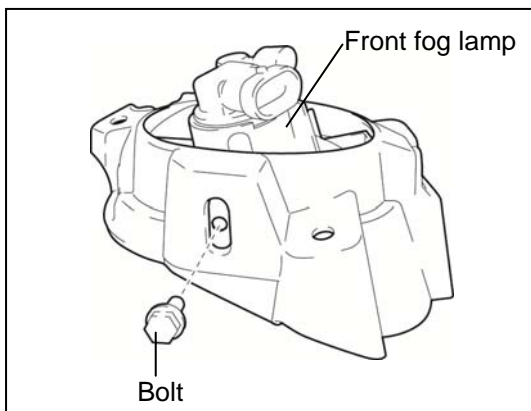

(5) Install the front fog light to the bracket and temporarily tighten the bolt.

(6) Install the front fog light.

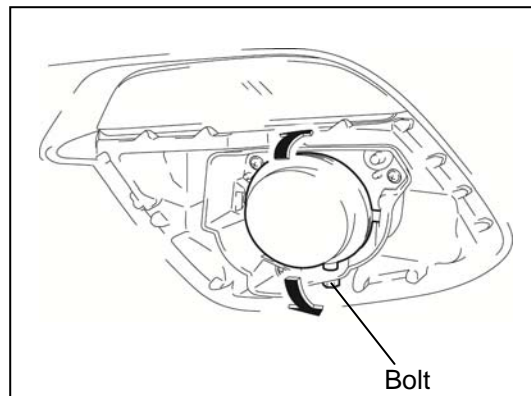

(7) Move the front fog light in the direction of the arrow shown in the figure and adjust the brightness border line until it has achieved the position indicated on the adjustment screen.

(8) Tighten the bolt.

**Bolt tightening torque : 1.0—3.4 N·m**

(9) Install the bezel.



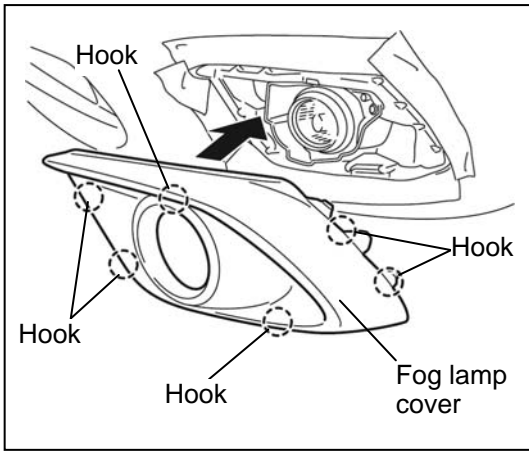

13. Install the fog lamp hole cover to the front bumper.

## 8. OPERATION CHECK







Connect the negative battery cable.

**Nut tightening torque : 4.0—6.0 N·m**

After connecting the negative battery cable, restore the vehicle functions .

- If the battery would be disconnected, some functions will no longer operate. See the vehicle workshop manual or owner's manual, and perform "Servicing after re-connecting the negative battery cable"

### Fog lamp operation check

1. Turn the headlight switch to  position, and check if the position (parking) lights are on.
2. Turn the headlight switch to  position, and check if the headlights are on.
3. Press the lighting control lever forward, and check if the high beams turn on.  
Check if the headlight high beam indicator light in the instrument cluster is illuminated when the high beams are turned on. Pull the lighting control lever back to its original position, and check if the high beams turn off.
4. Move the turn signal lever up/down, and check if the each turn signal flashes.  
Check if the turn signal indicator lights flash when the turn signal lever is in the up/down position.
5. Set the lighting control lever on the low beam position and turn the fog light switch to  position, then check if the fog lights turn on.
6. Turn the fog light switch to  position, and check if the fog light indicator light in the instrument cluster is illuminated.  
Turn the fog light switch to the OFF position, and check if the fog light indicator light turns off.
7. Turn the headlight switch to either  position or  position with the high beams, check if the fog lights turn off even with the fog light switch  in the position.
8. Turn the fog light switch to the OFF position or turn the headlight switch to the OFF position, and check if the fog lights turn off.

## 9. FOG LAMP BULB REPLACEMENT

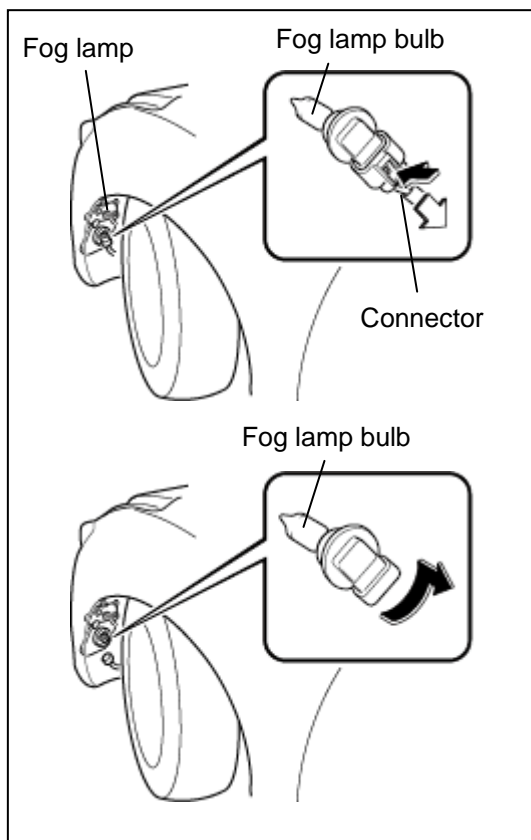

- If a non-specified fog light bulb is used it might cause a fire. Make sure to use the specified fog light bulb.
- Consult your dealer for fog light bulb replacement.
- Use the fog lamp bulb indicated below.  
Part number 90703 7550 [H11 12V 55W]
- When replacing a light bulb, always hold by the flange and do not touch the glass part of the bulb. Oil or grease adhering to the bulb decreases bulb life.
- For details, refer to the vehicle's owner's manual.

1. Peel back the mudguard.
2. Disconnect the connector from the unit by pressing the tab on the connector with your finger and pulling the connector downward.
3. Turn the fog lamp bulb in the direction shown in the figure and remove it.
4. Install a new fog lamp bulb in the reverse order of the removal.
5. Connect the connector to the fog lamp.

Date _____, _____, _____				
VIN _____				
Approved		Checked		Person in charge

<b>INSTALLATION INSPECTION SHEET</b>	<b>MAZDA3</b>	<b>FRONT FOG LAMP KIT</b>
		<b>BHN1 V4 600</b>

Perform the following inspections

**1. Inspection items after installation**

Check

- Verify the installation of the installed part, and inspect for damage or soiling.

Check

- When connecting connectors, verify the connection again to prevent poor connection or mis-connection. (Connect two times)

**2. Vehicle parts reinstallation**

Inspected part	Inspection item	Inspection	Check
Negative battery terminal	Torque change	Is the nut for the negative battery terminal tightened to the specified torque? <b>Tightening torque: 4.0–6.0 N·m</b>	<input type="checkbox"/>
Check if the light switch operates correctly. (Headlights, turn signals, other lights) Check if the light dispersion is correct.			<input type="checkbox"/>

**3. Installation of accessory, operation check**

Inspected part	Inspection item	Inspection (interior/exterior part)	Check
Check if the fog lamps turn on/off correctly.			<input type="checkbox"/>